

F 油门操纵  
F ACCELERATOR PEDAL

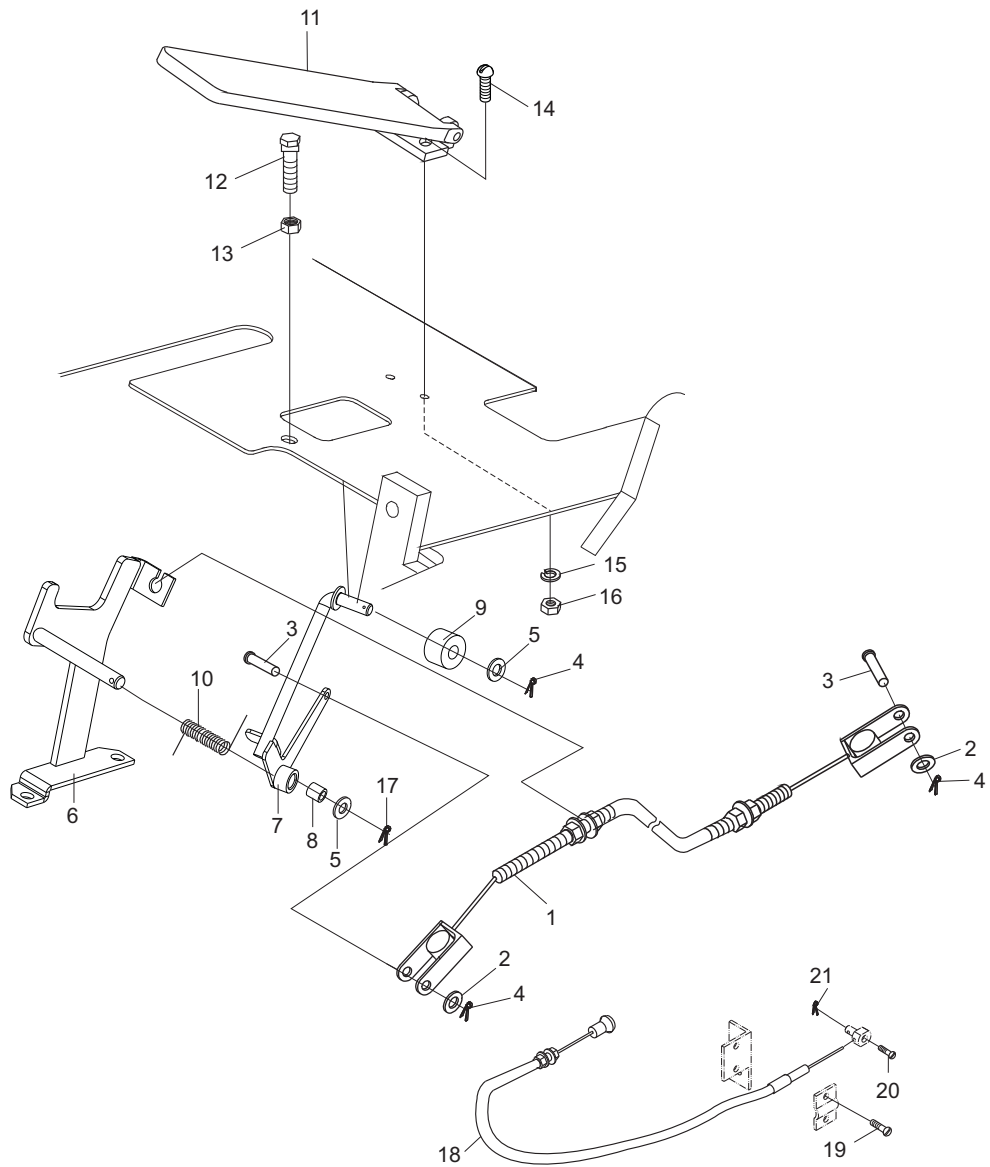

K3EA5-20001

F 油门操纵  
F ACCELERATOR PEDAL

序号 Item No.	图号 PartNo.	版本 Edition	零部件名称	Description	件数 Q'ty	备注 Remark	适用时间 Applied time
A	K3EA5-20001	00	油门操纵	Accelerator pedal	1		
01	H99Y5-20012	00	油门拉索	Accelerator cable	1		
02	B5310-00006	00	平垫圈A级6	Washer	2		
03	B3230-06016	00	销B6×16	Pin	2		
04	B3010-20020	00	销2×20	Pin	3		
05	B5310-00010	00	平垫圈A级10	Washer	2	GB97.1-85	
06	K3EA5-60401	00	支架	Bracket	1		
07	K3EA5-60301	00	连接轴总成	Connecting shaft ass'y	1		
08	Z2131-01015	00	钢背轴承1015	Bushing	1		
09	H2405-62021	00	滚轮	Roller	1		
10	HT995-62201	00	弹簧	Spring	1		
11	H2405-60201	00	踏板总成	Pedal ass'y	1		
12	25785-22111	00	螺栓	Bolt	1		
13	B4233-00012	00	螺母M12×1.25	Nut	1	GB6171-86	
14	B0330-06020	00	螺栓M6×20	Bolt	1	GB5783-86	
15	B5050-00006	00	弹簧垫圈6	Washer	1	GB93-87	
16	B4133-00006	00	螺母M6	Nut	1	GB6170-86	
17	B3010-3P220	00	销3.2×20	Pin	1	GB91-86	
18	K3EA5-20011	00	熄火操纵装置	Flameout control	1		
19	B1110-04016	00	螺钉M4×16	Screw	2	GB67-85	
20	B1110-04010	00	螺钉M4×10	Screw	1	GB67-85	
21	B3010-20010	00	销2×10	Pin	1	GB91-86	